

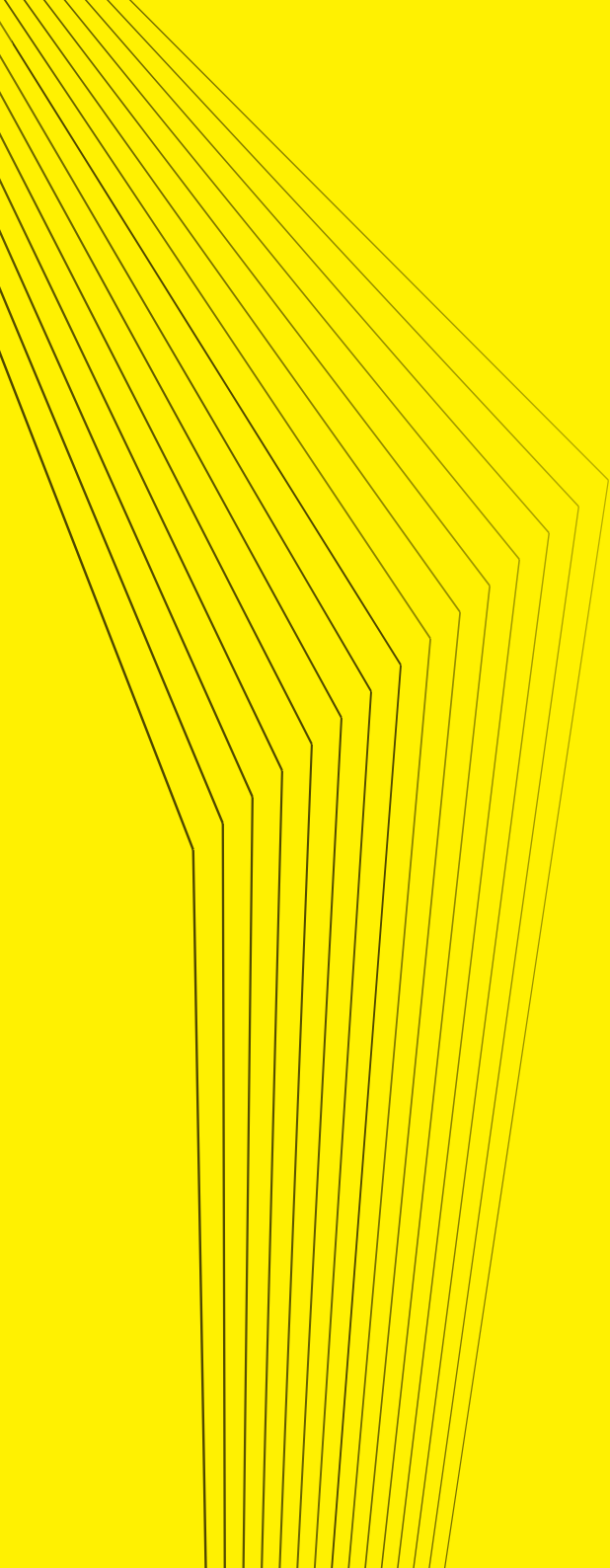



# Data spaces overview

Let's build the future data economy!





The International Data Spaces (IDS) standard creates the foundation for the future of a global, digital economy. It combines a technical architecture and governance models to facilitate the secure and standardized exchange and easy linking of data in data spaces. The IDS standard delivers data sovereignty. It allows companies and individuals to self-determine how, when and at what price their data is used across the value chain – and thereby enables new smart services and innovative cross-company business processes.





The IDS standard initiates a paradigm shift: companies can share any data in any ecosystem, which will ultimately transform the digital economy around the world. To identify requirements for the application of the IDS standard in business scenarios, members of the International Data Spaces Association (IDSA) develop use cases and even entire IDS-based data spaces that can host a wide range of use cases. These front-running data spaces and use cases show how the IDS standard adopts in real-life challenges and becomes a widely agreed and applied de facto standard.

# Strategic industry requirements determine the design of the International data spaces architecture



## *Trust*

1

Trust is the basis of the International Data Spaces. It is supported by a comprehensive identity management focusing on the identification of participants and providing information about the participant based on the organizational evaluation and certification of all participants.

## *Data markets*

6

The International Data Spaces enables the creation of novel, data driven services that make use of data apps. It also fosters new business models for those services by providing clearing, billing and the creation of domain specific brokers and marketplaces. In addition, usage restrictions and legal aspects are provided as templates and with methodological support.

## *Value adding apps*

5

The International Data Spaces enables app injection to connectors to add services on top of the pure data exchange. This includes services for data processing as well as the alignment of data formats and data exchange protocols, but also enables analytics on data by the remote execution of algorithms.

2

## *Security and data sovereignty*

Components of the International Data Spaces rely on current security measures. Next to architectural specifications, this is realized by the evaluation and certification of the components. In line with the central aspect of ensuring data sovereignty, a data owner in the international data spaces attaches usage restriction information to its data before it is transferred to a data consumer. The data consumer may use this data only if it fully accepts the data owner's usage policy.

3

## *Ecosystem of data*

The architecture of the International Data Spaces does not require central data storage capabilities. Instead, it pursues the idea of decentralization of data storage, which means that data physically remains with the respective data owner until it is transferred to a trusted party. This approach requires a holistic description of the data source and data as an asset combined with the ability to integrate domain specific vocabularies for data. Brokers in the ecosystem enable comprehensive realtime search for data.

4

## *Standardized interoperability*

The International Data Spaces Connector, being a central component of the architecture, is implemented in different variants and from different vendors. Nevertheless, each connector is able to communicate with every other connector or component in the ecosystem of the International Data Spaces.

# The International Data Spaces approach connects all kinds of data endpoints

When broadening the perspective from an individual use case scenario to a data space view, the IDS architecture becomes the link between different cloud solutions, platforms, marketplaces, and other data endpoints through secure exchange and trusted sharing of data, short: **through data sovereignty.**

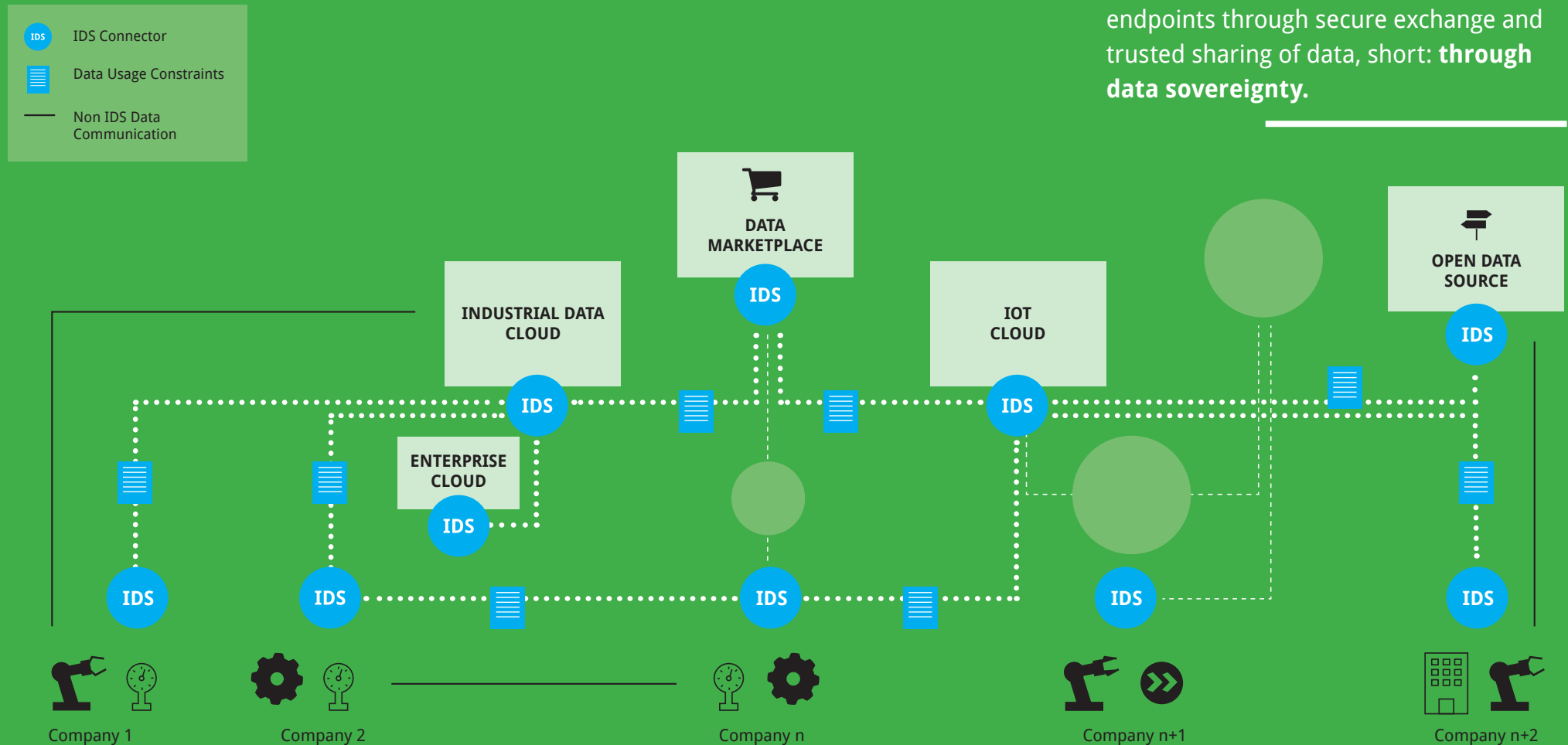

One software component connects all kinds of data clouds, platforms, and marketplaces - the IDS connector.

# Our Use Cases Make Data Spaces

Use cases are cross-company business processes enabled by the International Data Spaces standard. They help identify, analyze, and evaluate user requirements for IDS. More than that: by realizing a use case, companies drive innovation. They create the core of an ecosystem by engaging internal and external stakeholders in the development of smart value-added services. When data spaces are the engine, use cases are their fuel. They empower and accelerate the building of cross-domain and cross-country data spaces with thousands of participants.

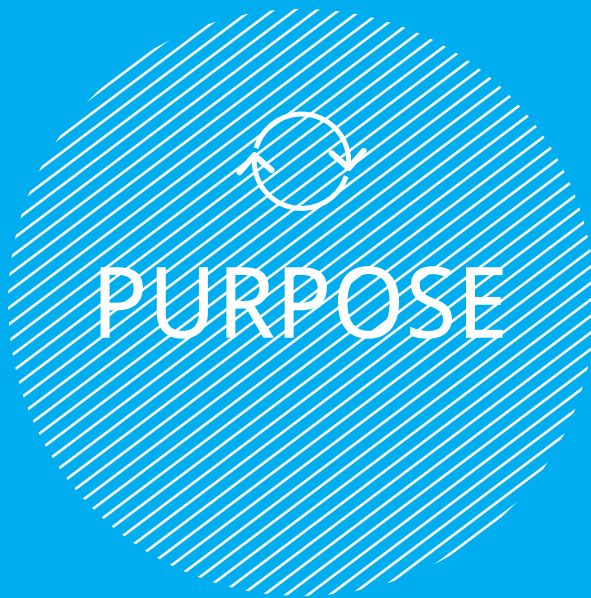

## *Getting Ahead Together*

Data spaces are built by companies. Members of IDSA can use the power of more than 130 companies, researchers and industry associations from over 20 countries all over the world. Together, they make IDS a reality.

IDSA members provide open-source software that is measured against the open standard. These align with domain-driven requirements and use tangible technologies that bring the IDS standard to life. Thanks to the members of IDSA, the IDS standard can be used wherever and by whomever data sovereignty is in need.

Use cases and data spaces cross security domains, they build trust and respect the data sovereignty of each data space participant.





**LET'S GO!**

*Time to build  
data spaces together!*





**Mobility Data Space**

*Combining data from all mobility actors and relevant real-time information to enable seamless, multimodal mobility for everyone*

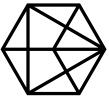

CHALLENGE

Intelligent traffic and mobility systems require a large amount of data in order to support decisions in the best possible way or even to make them automatically. Although countless mobility data are already collected and processed today, comprehensive utilization of these data is often not possible for technical, legal or economic reasons. The Mobility Data Space (MDS), an open IDS-based data space that goes beyond the secure exchange of sensitive mobility data, as well as linking existing data platforms with one another (cf. Mobility Data Marketplace – MDM). In this way, comprehensive mobility data can be made available in the future without fear of misuse of the data.

SUCCESS

The Mobility Data Space enables the sovereign handling of data for digital mobility solutions. Common legal frameworks based on European data protection guidelines form the basis for this. By linking offers from different mobility providers, individual mobility can be better combined with public transportation and sharing providers. New opportunities also arise for traffic control by municipalities when data from passenger cars are combined with parking space and local public transport data. Real-time information, for example, taking road works or traffic jams into account, allows flexible adjustment of routes for private and public transport.

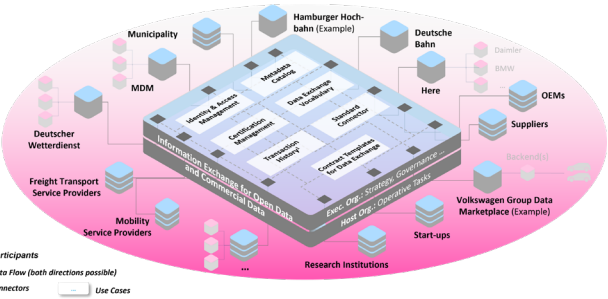

COMPONENTS

- IDS Identity Provider (CA, DAPS, ParIS)
- IDS Metadata Broker
- IDS App Store
- IDS Clearing House
- IDS Vocabulary Provider
- IDS Connectors (not provided by operating company)

BENEFITS



- » *Secures data sovereignty by establishing common rules for trustworthy data transactions*
- » *Reduces the economic and technical dependence on digital platforms of large private providers*
- » *Creates a basis for a cross-modal and intermodal mobility system*

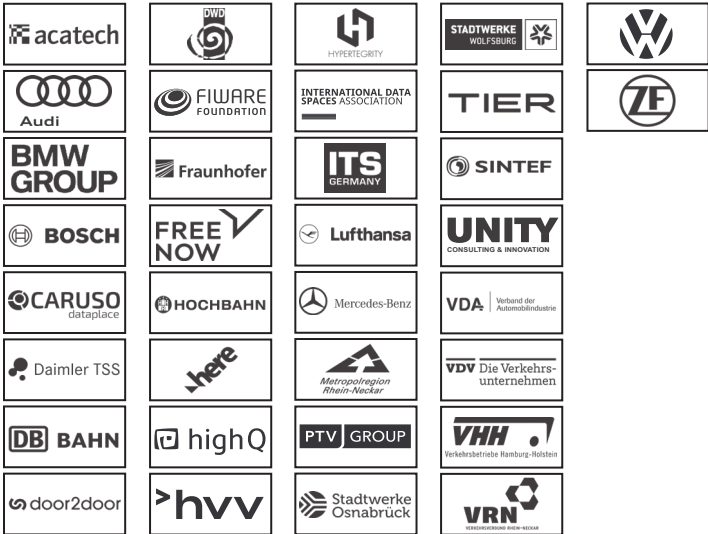

## PTV GROUP



# Better traffic forecasts through machine learning

*Mobility Data Space - use case #01*

### PROBLEM

- Traffic volume forecasts have so far been static, without taking current traffic patterns into account

### POSSIBLE DATA USERS

- Traffic management system operators
- Public or private

### SOLUTION AND ADDED VALUE

- AI determines typical daily patterns from established data with little effort and uses them for the forecast

### DATA USER

- Traffic count data from permanent counting points (or other time series), existing (training) and real-time (forecasting)

### POSSIBLE DATA SUPPLIERS

- Materna



## ZF GROUP

# Air quality measurement and forecasting

*Mobility Data Space - use case #02*

### PROBLEM

- Air quality is currently only measured selectively. Optimized traffic planning to improve air quality is only insufficiently possible.

### POSSIBLE DATA USERS

- e.g. cities and municipalities

### SOLUTION AND ADDED VALUE

- Forecast of local air quality based on dynamic traffic data
- Incorporation of the forecast into traffic control

### DATA SUPPLIER

- ZF Truck
- HERE, if applicable

### DATA BASIS

- ZF Truck

**AUDI**



## Decisions based on hazard information

*Mobility Data Space - use case #03*

### PROBLEM

- Drivers often get into dangerous situations on the road unexpectedly and unprepared

### DATA BASIS

- Vehicle sensor data on local danger spots (accidents, black ice, heavy rain, etc.) with geo-position and timestamp

### SOLUTION AND ADDED VALUE

- Real-time vehicle data on road damage, accidents, etc. are used to warn other road users
- Drivers can proactively make appropriate driving decisions or be rerouted if necessary

### POSSIBLE DATA USERS

- Automotive suppliers, navigation providers, cities and municipalities, weather services, insurers

### DATA PROVIDER

- AUDI AG



**CARUSO**

## Sustainable use of electric drives for PHEV vehicles

*Mobility Data Space - use case #04*

### PROBLEM

- For tax-advantaged hybrid vehicles, it is unclear to what extent electric driving is used

### DATA PROVIDER

- CARUSO

### SOLUTION AND ADDED VALUE

- Derive actual usage and sustainability from telematics data of hybrid vehicles

### VISION FOR EXPANSION

- Further use of data by vehicle users, companies or tax offices

### DATA BASIS

- Telematics data of vehicles

### DATA USER

- ZF Group



A child in a blue shirt and dark pants is riding a scooter on a road. The road is marked with numerous white, wavy lines that create a sense of motion and depth. The child is positioned in the lower-left quadrant of the frame, moving towards the right. The background consists of these wavy lines that curve and recede into the distance, creating a dynamic and abstract visual effect.

**MDM - Mobility Data Marketplace**

*Interactive portal for offering,  
researching and maintaining  
mobility data*





## CHALLENGE

Digitization is driving new mobility concepts. Traffic and mobility data are becoming the raw material for multimodality, automated and connected driving, and other future solutions. The MDM is right in the middle of the action.

## SUCCESS

Whenever you aim to provide or find high quality mobility data in Germany, you can hardly get around the Mobility Data Marketplace (MDM). As a neutral B2B platform MDM offers suppliers and users of mobility to share, search and subscribe to traffic-relevant online data.

With its defined standards for data exchange – based on IDS components, MDM is the nation's biggest volume of information on traffic flows, traffic jams, road works, mobility options, parking facilities and more.

The MDM is continuously working to make as much mobility data as possible accessible, across different means of transport, network elements and actors. This includes mobility data that is offered at the same time on other data portals in Germany, e.g. geoportal.de, mCLOUD.de, open-data-oePNV.de. Such parallel data offers will gradually be made visible on the MDM as well. The evolution of MDM will also lead to an alignment with the Mobility Data Space (MDS) which will grant data sovereignty for MDM customers beyond the border of the marketplace and open up the entire marketplace to participants of MDS.

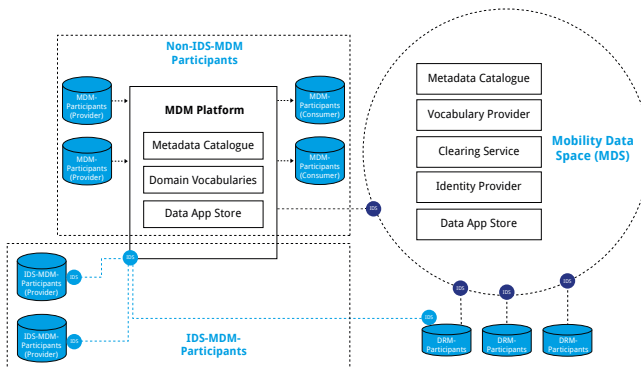

## COMPONENTS

- IDS Connector
- Metadata Catalogue
- Data App Store
- Domain Vocabularies



## BENEFITS

- » Better traffic management through exchange of traffic data with other municipalities
- » Noticeable relief due to low organizational effort
- » High transparency and security through unified standards
- » High degree of dissemination of data in end-user devices through easy access for service providers
- » Improved business opportunities through easy access to the market for traffic data
- » New research impetus through broad, easily available data supply

Catena-X

*Secure and trustworthy data  
infrastructure for automotive  
network*





### CHALLENGE

The goal of Catena-X is to create the first uniform standard for data exchange along the entire automotive value chain. The IDS standard is the blueprint for data exchange based on European values, such as data protection and security, equal opportunities through a federated design and the guarantee of data sovereignty for the creator of data and trust between participants.

### SUCCESS

With the IDS standard as the essential infrastructure basis, Catena-X will be an extensible ecosystem in which automotive manufacturers and suppliers, dealer associations and equipment suppliers, including the providers of applications, platforms, and infrastructure, can all participate equally.

### COMPONENTS

- IDS Identity Provider (CA, DAPS, ParIS)
- IDS Metadata Broker
- IDS App Store
- IDS Clearing House
- IDS Vocabulary Provider
- IDS Connectors

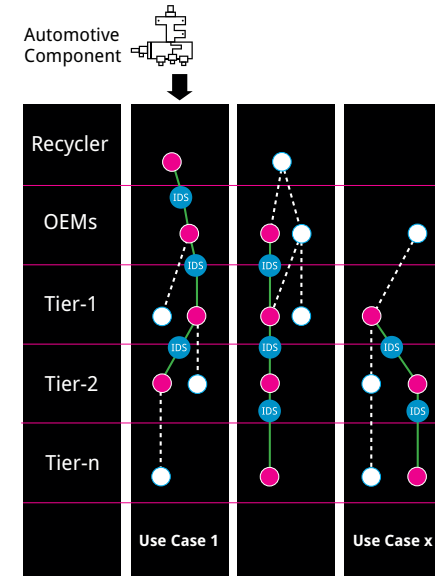

### BENEFITS



- » Creates an important starting point for the industry to respond more efficiently to the challenges of digital transformation
- » Increases the automotive industry's competitiveness
  - » Improves efficiency through cooperation
  - » Accelerates company processes through standardization and access to data



A photograph of a modern industrial factory floor. In the foreground, a dark grey conveyor belt with yellow safety lines runs towards the background. On either side of the conveyor, several white robotic arms with yellow cables are positioned. The background shows a large, bright industrial space with high ceilings and windows. The overall scene is clean and organized, representing a high-tech manufacturing environment.

SCSN

*Connect once – communicate with everyone*



## CHALLENGE

Smart Connected Supplier Network is an initiative of manufacturing companies and their IT-suppliers in the high-tech manufacturing supply chain. The aim is to facilitate cross-factory communication and thus ensuring supply chain transparency and interoperability, resulting in an overall productivity improvement of 20%. This is realized by reducing the administrative burden and facilitating collaboration between supply chain partners.

Unlike traditional centralized platform initiatives, SCSN is fully based on the principles of digital and data sovereignty. There is no central entity controlling the data. A non-profit foundation chairs the data sharing agreements, but the implementation is done by the involved IT-suppliers. Unlike existing EDI-initiatives, these agreements not only address the semantics, but also the technical and legal aspects between partners in the ecosystem.

## SUCCESS

SCSN is designed as a highly scalable solution by providing a network approach (four-corner model) which consists of the following two aspects:

- One **common semantic language** to exchange: orders, forecast, TPDs, BoM, drawings, invoices, logistical information, catalogues, and measurement data.
- Seamless **technical agreements** between service providers to ensure the promise of connecting once – communicate with everyone. The underlying SCSN infrastructure is based on the reference architecture developed by the International Data Spaces Association. The SCSN Foundation created standard IDS connectors and data apps, which can be used by service providers. These service providers, i.e. integrator parties, created off-the-shelf integrations with a complete portfolio of ERP systems. This way, they can very easily connect manufacturing companies to the network.



## BENEFITS

- » *Seamless scalable integrations for manufacturing companies for exchanging purchase-to-pay information*
- » *Reduction in administrative burden, faster time-to-market, lower IT integration costs*
- » *IT service providers only need a single integration*

## COMPONENTS

- IDS Identity Provider (CA, DAPS, ParIS)
- IDS Metadata Broker
- IDS Clearing House
- IDS Connectors
- Data Apps

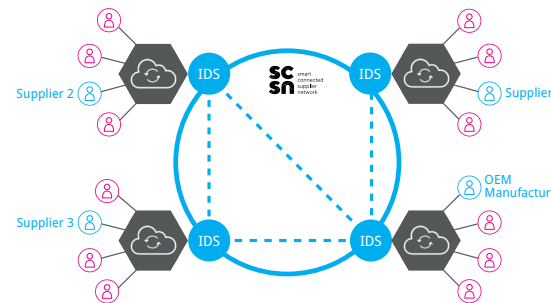

Service Provider  
Any company that needs to share ERP data easily in a sovereign way



A close-up photograph of industrial machinery, showing a hexagonal nut and a bolt. The metal is dark and shows signs of wear and rust. The nut has the number '2' engraved on it. The bolt is partially visible, with its threads and a hexagonal head. The background is dark and out of focus.

**Boost 4.0**

***Boosting big data applications  
for Industry 4.0 with a European  
Industrial Data Space***

## CHALLENGE

Boost 4.0 is the biggest European initiative in big data for Industry 4.0, with a 20M€ budget that will leverage over 290M€ of private investment. The 53 partners of the consortium have set the foundations of a sovereign manufacturing oriented European Industrial Data Space (EIDS) in a realistic, measurable and replicable way. The EIDS architecture was aligning with the International Data Spaces (IDS) reference architecture model.

Boost 4.0 has also contributed to the creation of cooperative big data ecosystems widening the European network of digital hubs and setting up the Digital Factory Alliance, an initiative to offer over the next years a community where European industry, specially SMEs, can find all they need to embrace the big data transformation of Industry 4.0.

## SUCCESS

- Contribution to the international standardization of European Industrial Data Space data models and open interfaces aligned with the European Reference Architectural Model Industry 4.0 (RAMI 4.0).
- Through 11 lighthouse factory trials and 2 replication ones, Boost 4.0 has leveraged 2 open source (OSS) reference implementations of sovereign data connectors, 1 certification model and 1 integration camp facility for open validation and verification of manufacturing data space software components

## COMPONENTS

- IDS Identity Provider (CA, DAPS)
- IDS App Store
- IDS Connectors



## BENEFITS

- » *Numerous benefits for the 11 factory trials including increase of overall equipment effectiveness (OEE), improvement of quality and reduction of maintenance activities*

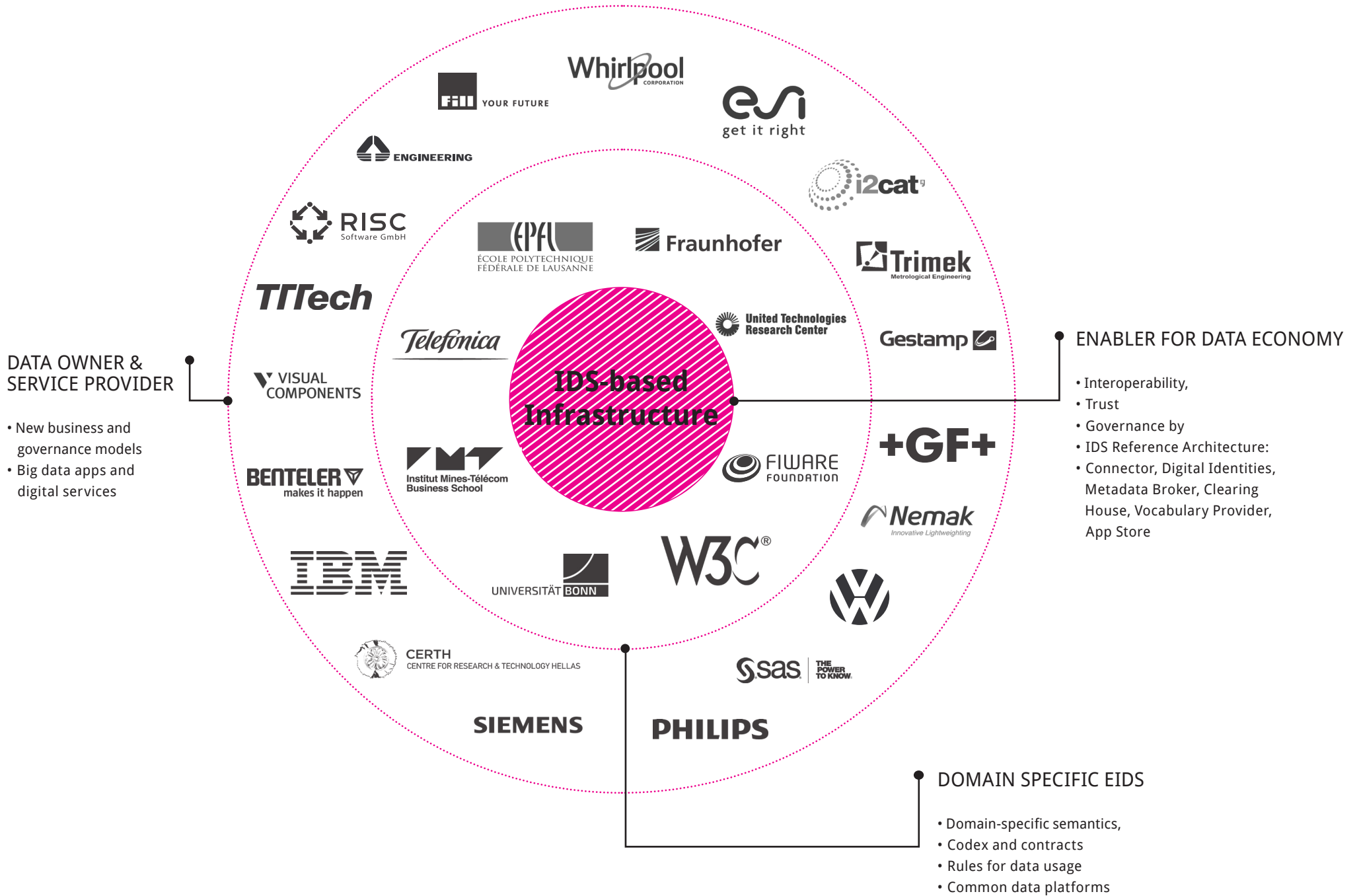

## Boost 4.0



# Data sovereignty and access management - CRF autonomous assembly line factory 4.0

Use case #01

## Boost 4.0



# Transform brownfield casting processes into an industry 4.0 compliant data space

Use case #02

### PROBLEM

- Flexibility and scalability are key features for data acquisition in the manufacturing industry and they are mandatory for a platform for big data analysis and collection. Such a platform must be accessible by a great number of data sources within the plant by means of connectors and connectivity devices, and provide security accessing the data.

### DATA PROVIDER

- FCA

### SOLUTION AND ADDED VALUE

- The FCA autonomous assembly line trial considers as key figures for the data sovereignty and access management the following elements: data ingestion rate, number of authorized users, data storage and security protocols implementation.
- In order to access the platform, the Boost 4.0 reference architecture defines data sovereignty requirements in terms of roles and authorizations provided to its users. The platform can host a limited number of users depending on its infrastructure.

### DATA BASIS

- Time series
- Events
- Alarms
- Machine states

### PROBLEM

- In the manufacturing industry, the big data approach is increasingly demanding the expansion and optimization of foundry lines. The imperative need to optimize the casting process as well as to achieve zero defect products entails the requirement for increasing quality in casting and resulting parts as well as reducing costs of production.

### DATA PROVIDER

- Nemak

### SOLUTION AND ADDED VALUE

- One enabler for achieving this is the transformation of brownfields into Industry 4.0 compliant data spaces. This transformation enables the exploitation of available data through direct (raw or preprocessed) data provision or data analytics services that provide their functionalities as user friendly assistant systems in the smart manufacturing environment. The specific challenge of this business process was the additional gathering and linkage of process data in the Nemak foundry.

### DATA BASIS

- Structured manufacturing data





**DASLOGIS**

*Offering real-time visibility  
of sensitive data to the logistics sector*





## CHALLENGE

To adapt to changing market dynamics, organizations are collaborating more than ever in increasingly complex and agile supply chains, requiring a flexible exchange of many (often commercially sensitive) data sets with a variety of stakeholders. Organizations in logistics are currently developing and implementing digitization strategies to adapt and prepare to extract value from these opportunities. However, the scale of the challenge transcends the boundaries of organizations. This project builds on the work and analysis of the needs, approach, positioning and roadmap for a Dutch logistics data space in the recently published white paper on the logistics infrastructure for data sharing.

## COMPONENTS

- IDS Connector
- IDS Essential Services

## SUCCESS

Motivated because of conclusions from the white paper and previous research, the need for a Dutch Logistics Data Space (DLDS) was identified. This extends the limited functions of current logistics agreement framework approaches (such as iSHARE) and meets international developments and standards as they apply to other sectors in increasingly interconnected supply chains. That is why the DASLOGIS project aims to develop a DLDS: a digital virtual environment or ecosystem that enables the finding and controlled sharing of (potentially) sensitive data. It offers flexibility, extensibility, and personalization to support the three main types of logistics data exchange: "sharing transaction data for operational optimization," "sharing (big) data for data analysis," and "supply chain data sharing for real-time visibility."

DLDS will be based on the generic and internationally standardized reference architecture model, supplemented and adapted to Dutch logistics needs where applicable. The proof of concept (PoC) of the DLDS is validated using three functional prototypes. The project partners will also demonstrate and assess the technical feasibility and business value of a DLDS for the Dutch logistics sector based on logistics use case.



## BENEFITS

- » *Enables the discovery and controlled sharing of (potentially) sensitive data*
- » *Offers flexibility, extensibility and personalisation to support data exchange in logistics*





Metal domain data space - M4.0

*Optimizing equipment selection in  
the metal manufacturing domain*



## CHALLENGE

Selecting the most suitable new manufacturing equipment is a time-consuming challenge for many customers. There's no easy way to digest all available information about options, so customers must browse the internet, attend trade shows and talk to multiple experts in order to reach an informed decision. We wondered if data spaces could help integrate and streamline this process - focussing specifically on the metal domain.

## SUCCESS

The MARKET 4.0 Metal Domain Data Space is based on the IDS Reference Architecture Model (RAM). It describes a robust and efficient solution for linking the inventories of different equipment manufacturers to a MARKET 4.0 service that analyzes the customer's requirements and returns the most suitable equipment options for a certain metal domain manufacturing process. The connection is made through IDS connectors and the inventories and services include essential IDS modules (i.e., clearing house, metadata broker) that guarantee a trusted data exchange.

## COMPONENTS

- IDS Connector
- IDS Clearing House
- IDS Metadata Broker
- Special Applications
- Central IDS compliant platform



## BENEFITS



- » *The MARKET 4.0 Metal Domain Data Space makes the selection of manufacturing equipment simpler and more efficient, getting to a better result in less time*
- » *It is flexible, offers two solutions:*
  - 1. Connecting equipment manufacturer repositories with a single IDS connector. The equipment manufacturers do not require knowledge of the IDS RAM. Only the connector owner needs to have it.*
  - 2. Connecting one service with multiple data providers/IDS connectors. The benefit of this is that the data provider controls the data flow and is independent of the connector provider.*



Ö-Cloud

*Government compliance certification  
based on IDS*





## CHALLENGE

Handling data is a crucial success factor for digital transformation. When it is shared and reused, data does not become less, but provides new information and applications. If Austria (and Europe) succeed in making even better and more targeted use of the treasure trove of data, this will bring greater innovative strength, higher competitiveness and better resistance to crises.

The Federal Ministry for Digitization and Economic Location of the Republic of Austria (BMDW) offers support to companies and research Institutions on the topic of Gaia-X as part of the Ö-Cloud initiative. The overall goal is to strengthen the digital sovereignty of Austria.

## COMPONENTS

- IDS and Gaia-X compliant infrastructure



## SUCCESS

msg as an IDSA implementation partner has supported the ministry and the participating companies by a) providing an overview about technical structure of compatible data spaces across domain boundaries, b) infrastructure consulting for the operation of IDSA and Gaia-X compliant architectures, c) aligning and positioning use cases regarding their specific role in the Gaia-X ecosystem.

With the Ö-Cloud Initiative, the BMDW promotes secure data management and data use by Austrian companies. To this end, the association of domestic cloud providers to form a digital security network is supported. Providers of cloud services in Austria complete a self-evaluation according to strict and transparent security standards. For this, they receive the Ö-Cloud seal of approval.



## BENEFITS

- » *The use of secure cloud applications and innovative services creates new economic opportunities for companies*
- » *More data sovereignty: Your own data remains where you want it - in Austria, Europe or beyond*
- » *The data is securely stored and managed according to strict standards (e.g. DSGVO)*
- » *The Ö-Cloud Initiative facilitates cooperation with other European cloud providers (GAIA-X) and gives domestic providers a competitive edge*
- » *Austria is strengthened as a location for the data economy and becomes more attractive internationally*

Energy data space

*Optimizing the data value chain for  
green hydrogen production over long  
distances*



HYDROGEN  
ENERGY  
STORAGE





### CHALLENGE

The digitization of the energy transition aims to harness information from a large number of decentralized power generators. With the prospect of green hydrogen gaining importance in the energy sector, the sources of electricity supply for the electrolysis of hydrogen is important. Operation of electrolyzers need to consider availability of green electricity, actual power prices and grid situation. In this use case wind power should be used for hydrogen production when the resource is available.

### SUCCESS

Communication between the plants and systems takes place via an energy data space. Here, plants exchange data according to agreed rules and under certain conditions. An IDS connector implements these rules and processes. The concept of International Data Spaces thus enables all players to make self-determined decisions about the use of their data, thus enabling their digital sovereignty.

The turbine operator provides a data resource with operational data via an IDS connector. An energy management system from a third party provides the digital service to create an optimized schedule which is then sent to the electrolyzer for operation.

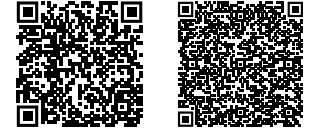

### COMPONENTS

- IDS Connector
- IDS Identity Provider (CA, DAPS, ParIS)
- FIWARE platform linked through connector



### BENEFITS

- » Provision of operational wind data resource
- » Digital service for Calculation of an optimized schedule
  - » Proof-of-concept with real world assets
- » Data communicated through IDS-connector into FIWARE platform

DAEKIN

*Increasing wind energy efficiency  
through improved value chain  
collaboration*



### CHALLENGE

A very important aspect of the competitiveness in the wind farms is the maintenance of all the components of the wind turbine. Only wind farm developers and wind turbine manufacturers (OEMs) have access to data collected from operating wind turbines and are therefore the only actors currently working on extracting added value from data at the "top of the value chain". Therefore, most European wind turbine component suppliers, engineering companies or ICT companies cannot obtain, manage, analyse, and learn from the data produced by wind turbines in operation, thus missing the opportunity to improve their competitiveness

### COMPONENTS

- Eclipse DataSpace IDS Connectors
- Fraunhofer AISEC Identity Provider
- Fraunhofer AISEC Clearing House
- Tekniker own Vocabulary Provider for Offshore Wind Energy



### SUCCESS

The use case shows how the adoption of the IDSA Architecture boost the exchange of the data monitored by the sensors installed in wind turbines, which belong to the wind farm owner and the OEM, with other interested third parties such as technology and component suppliers, as secure data exchange and data sovereignty is guaranteed.

Furthermore, it is also shown how this data sharing enables added value creation through information fusion. The deployment of the solution combines edge processing with the cloud demonstrating its applicability in wind turbine plants.



### BENEFITS

- » *A deeper understanding of the technical characteristics and performance of the wind turbines' critical systems and components.*
- » *Developing a highly skilled and competitive supply chain*
- » *Less investment in data analysis systems thanks to the collaboration and support of specialized suppliers with in-depth knowledge of the technical characteristics and performance of the components supplied*

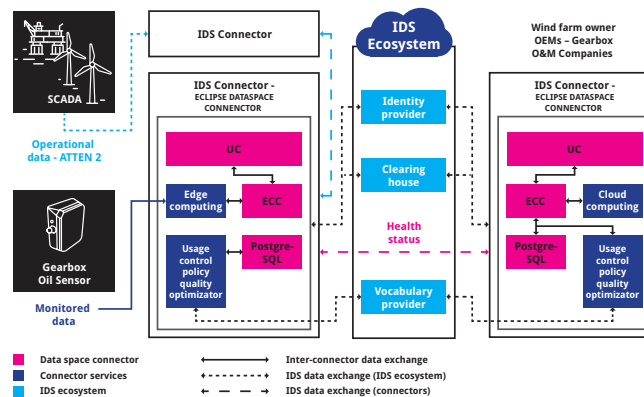



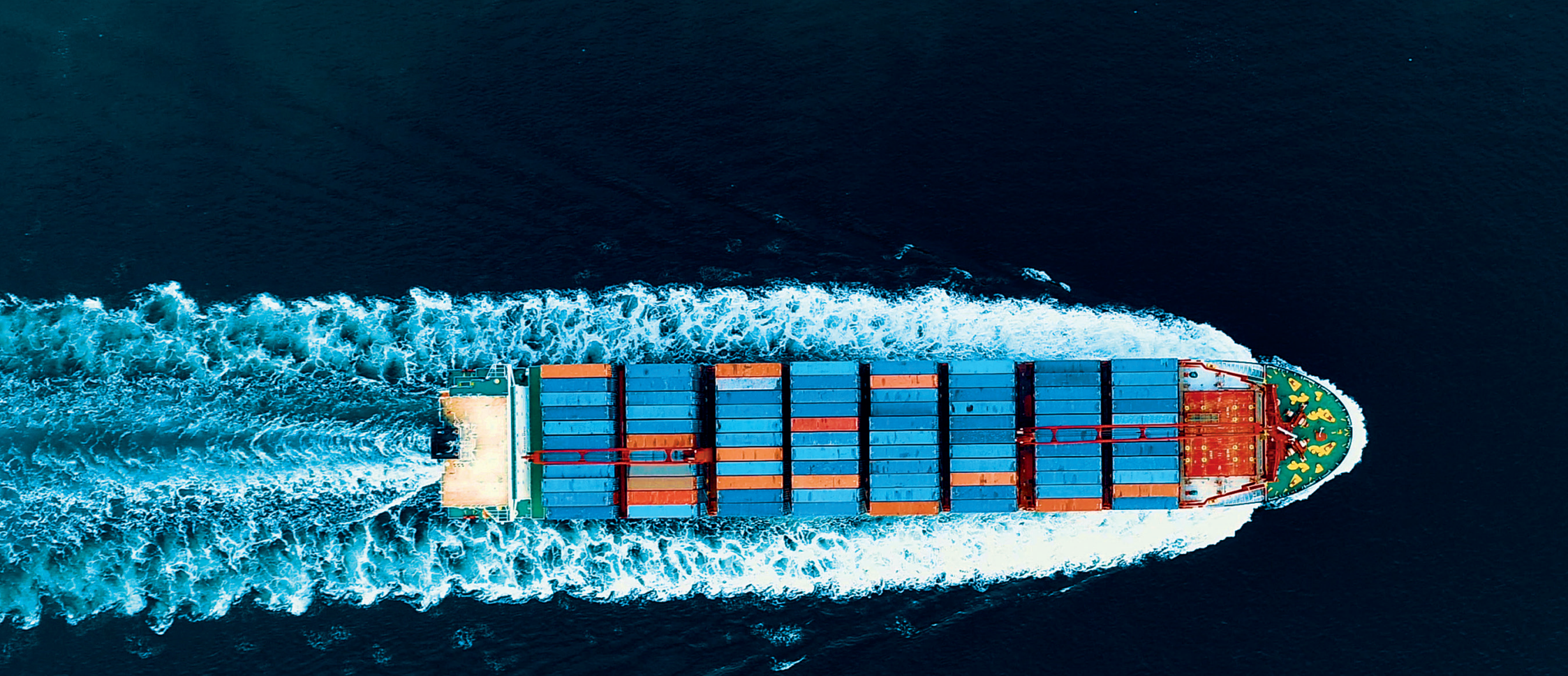

SINTEF

*Ecosystem makes a wealth of vessel data accessible and marine traffic more efficient*





## CHALLENGE

Maritime shipping companies are required by law to transmit a set of important data before entering every port. There are various industry solutions for this data exchange such as the Veracity ecosystem in the market today. All of them are very complex and time intensive to manage.

Providers and organizations on shore do not have access to ship data like emissions, fuel consumption and route details. Data access agreements between data providers such as ship owners, authorities or shipyard equippers, as well as service providers that take care of data analysis and process improvements must be negotiated individually.

A common ecosystem for data exchange from ship to shore, that simplifies the process does not exist.

## SUCCESS

The IDS-based Maritime Data Space brings together all participants and platforms in one trusted and secure data ecosystem. It ensures transparent access to ship-related data, enables secure, stable and efficient communication between ship and shore, and provides value-added and trusted services for ship operations.

Autonomous shipping, environmental sustainability, Industry 4.0 technologies, and the connection between ships are current trends that the Maritime Data Space addresses in an innovative way. The combination of the Norwegian DNV GL Veracity data platform with an IDS-based ecosystem strengthens Norway's position in international maritime data exchange and sharing.

Last but not least, the Maritime Data Space satisfies customer and regulatory demand for transparency.

## COMPONENTS

- Veracity Industry Data Platform
- IDS Connectors
- IDS Identity Provider (CA, DAPS, ParIS)
- IDS Metadata Broker



## BENEFITS

- » *Transparent access to all relevant ship related data*
- » *Secure, robust and efficient communication between ship and shore*
- » *Simplified provision of trusted services for ship operation*
- » *Interoperability and data sovereignty for all involved parties*

Reallab HH Hamburger Hochbahn

*Enabling unprecedented  
individual door-to-door mobility  
between Hamburg and Berlin*







## CHALLENGE

To leverage the potential of intermodal travel, seamless integration of all mobility options in one user application is crucial. This application requires data interoperability and data sharing between multiple providers, such as different platforms and mobility providers, who have so far been reluctant to share their data, also for fear of competitive disadvantages.

## SUCCESS

In the RealLab Hamburg, the digital mobility of tomorrow is being tested in the here and now of a German metropolis. Based on this, a blueprint for the mobility of the future is to be created. At the center stands the social debate on digital mobility services in order to provide important insights into which approaches will prove themselves in practice.

A planning app for door-to-door travel between Hamburg and Berlin will be realized as a demonstrator using the IDS and Gaia-X data sovereignty standard. The IDS based data space creates advantages for all stakeholders. Citizens benefit from improved travel options, mobility providers from new business opportunities.



## BENEFITS

- » *Improved mobility through digitalization & automation*
- » *Reduction of traffic & emissions*
- » *Increasing mobility & traffic safety*

## COMPONENTS

- IDS Connector



NTT

*Selecting the production site  
with the lowest CO<sub>2</sub> emissions –  
across national borders*



### CHALLENGE

Data sharing across countries, industries and companies can help solve major social issues that are mentioned in sustainable development goals, as well as help create new digital businesses. However, structural problems such as confidentiality and trust, as well as the global trend for better data protection, have largely prevented companies from freely sharing and exchanging data in ways that would help to solve these problems. One important example is climate change, and our use case is specifically aimed at this issue.

### SUCCESS

In order to enable data to flow freely, NTT has been working on ensuring protecting data sovereignty and ensuring cybersecurity by using Smart Data Platform with Trust. This platform is a data infrastructure, developed by Japanese telecommunications carrier NTT, that enables secure and trusted data sharing based on consensus among stakeholders. Using the Smart Data Platform with Trust, NTT has built a testbed among Japan, Switzerland, and Germany for demonstrating a use case of CO2 reduction and circular economy. This use case visualizes differing power consumption for the production of drones at different locations. To do this, it uses trusted data exchange from manufacturing processes in Germany and Switzerland. This testbed also demonstrates that data sharing between Japan and Europe is possible when partners use GAIA-X and IDSA's core technology: the IDS Connector.

### COMPONENTS

- NTT Smart Data Platform with Trust
- IDS Connector (Fraunhofer Dataspace Connector)
- IDS Identity Provider (CA, DAPS, ParIS)
- IDS Metadata Broker
- IDS Clearing House
- OPC UA
- Things Cloud
- MindSphere

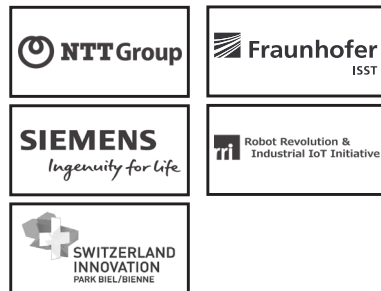

### BENEFITS

- » *Enables trusted and sovereign data sharing across international borders, industries and companies*
- » *Supports solutions for major global social issues, such as climate change*
- » *Enhances cooperative and sustainable value creation*



An aerial view of a city with various icons overlaid. The icons include a globe, a network of nodes, a binary code arrow, a headset, a crosshair, a smartphone, a speech bubble, a refresh symbol, and a mobile app icon. The background shows a dense urban landscape with various building styles.

Vastuu & VTT

*Improving transport, logistics and energy consumption to make Helsinki the best city to live*





CHALLENGE

In Helsinki, we share the aim of many global cities, to be more liveable, sustainable and inclusive. smart city could help achieve these goals by using technology and data sharing to improve mass transit, waste management and other municipal services; enable more inclusive participation of citizens in our democracies; and solve problems like parking, pollution and more. But making our cities smarter is complex and requires comprehensive multimodal data solutions to create broader understanding of heterogeneous data assets. The challenge we face is that data markets and economies are fragmented, with information isolated in systems and devices. Data lakes and spaces together with soft infrastructure are here to help, but we needed to figure out how to implement models that are scalable and robust enough to be ready for adoption.

SUCCESS

Focusing on decision-making around transportation as an area of critical importance, we sought to build a proof of concept for many-to-many connections that could be utilized in a smart city context. Our case involved two data lakes – one associated with energy use, the other with transportation and logistics. With the help of common design principles, an ecosystem, a layered approach and building blocks, we were able to connect different parties together and make trusted and harmonized data sharing a reality. In this case, the result could be improved information around decision-making for transportation, but it is easy to see how this generalizes to other smart city scenarios where acquiring and integrating different data sources enables better decision-making, innovation and new service creation.



BENEFITS

- » *Drives Europe's data economy*
  - » *Next-level adoption and co-creation of value with commercial scenarios*
- » *Fosters neutrality, standards and common language to avoid risks and enhance trust*
  - » *Helps establish the community and ecosystem to foster future innovation*

COMPONENTS

- IDS Connectors
- IDS Identity Provider (CA, DAPS, ParIS)
- Data harmonization and case-specific ontologies



Collaborative warranty And quality management

# *Making quality issue data transparent and available up and down the entire value chain*

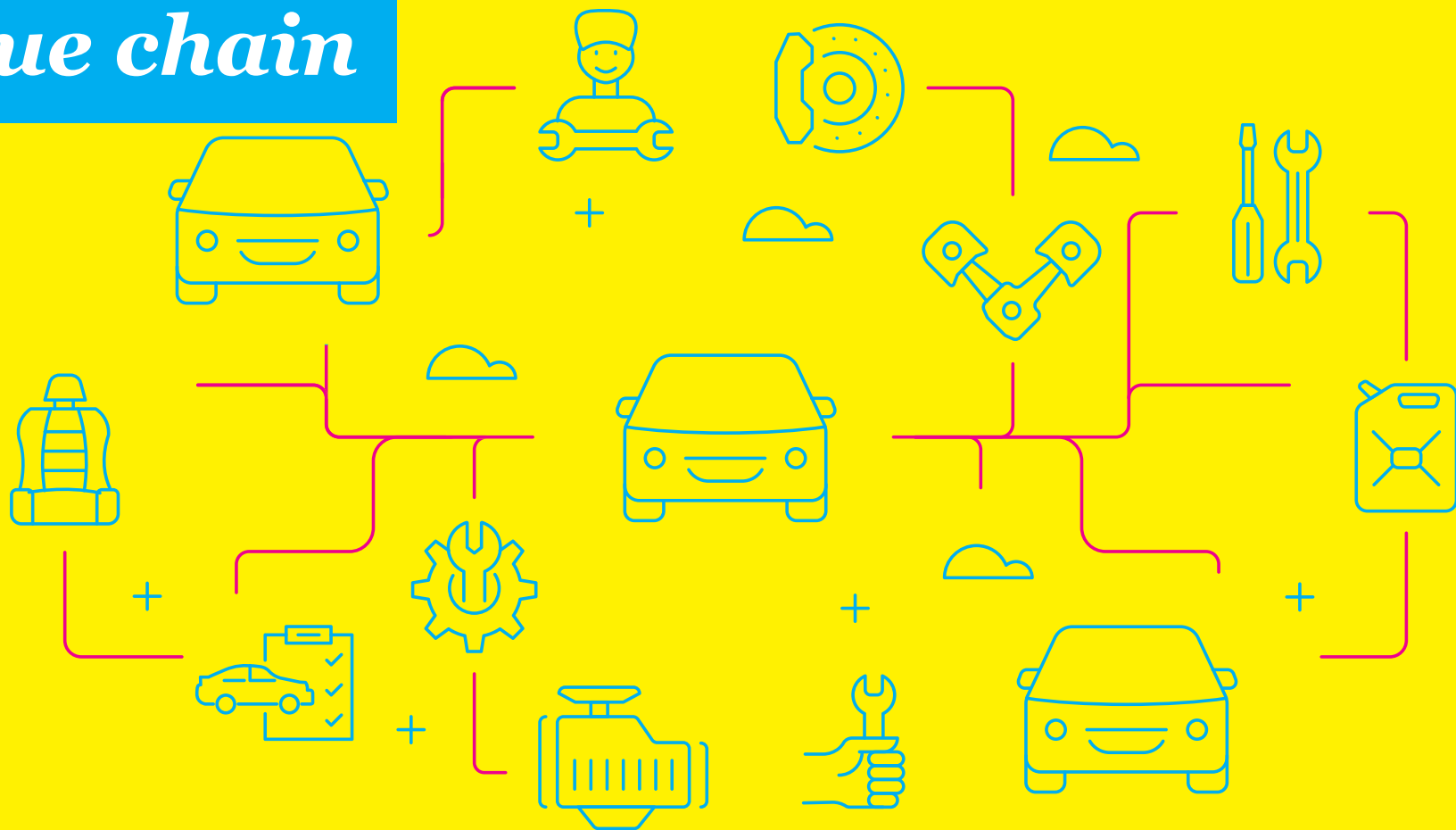



## CHALLENGE

In multitier supply chains, sharing of quality management data is delayed. The delay is caused by repeated data accumulation before information is passed on to the next tier. In consequence, systematic quality defects are uncovered too late leading to ongoing production of defective assets. Furthermore, due to a lack of incentives, desired data is not always shared. For example, in the automotive context, quality issues discovered in repair shops may reach the manufacturers only when the issues occur in the context of a warranty claim.

## SUCCESS

SAP wants to make use of IDS data sharing concepts to improve business processes by providing smart data apps which facilitate intercompany collaboration. The example of the „collaborative warranty and quality management“ apps illustrate how repair shops are incentivized to share vehicle quality data along the manufacturing supply chain, irrespective of their relevance for warranty claims. Suppliers of any tier gain transparency of quality issues from different downstream branches. When suppliers perform a root cause analysis of such issues, they can integrate downstream or upstream quality and usage data which is shared subject to usage policies.

## COMPONENTS

- IDS Trusted Connector
- SAP IDS App Store
- SAP S/4 HANA
- IDS Usage Control (MYDATA)



## BENEFITS

- » *Increases exchange of quality data along the supply chain*
- » *Timely discovery of evolving quality issues*





**Industrial additive manufacturing service**

*Trustworthy ecosystem for transfer of  
valuable and IP-relevant engineering  
data*

## CHALLENGE

In recent years, additive manufacturing technology has experienced double-digit growth rates in various industrial sectors, such as automotive, aerospace and medical technology. This trend is expected to continue in the coming years. As additive manufacturing and the digitalization of production processes continue to grow, they pose new challenges for the manufacturing industry in terms of protection of data and intellectual property as well as confirmability and traceability. The industry needs a decentralized solution that can ensure data sovereignty of data usage. This applies even more since manufacturing is becoming more and more decentralized, as it is conducted within global networks and parts are produced where they are needed.

## SUCCESS

thyssenkrupp and IBM together with Fraunhofer ISST have developed a prototype that builds the foundation for further expansion of an industrial manufacturing platform. The combined use of IDS technology and blockchain is intended to enable a higher degree of automation within the additive manufacturing process, as well as to provide data security and data sovereignty.



## BENEFITS

- » *Creates a trustworthy ecosystem for transfer of valuable and IP-relevant engineering data*
- » *Processes industrial AM orders in a fast, traceable and reliable manner*
- » *Protectes IP rights and ensuring product quality*

## COMPONENTS

- IDS Base Connector
- Blockchain technology (Hyperledger Fabric)





Silicon economy

*Trust along complete supply chains for  
logistics services and supply*



## CHALLENGE

In the coming years, the most successful business models in logistics will come from the platform economy. For individual companies, however, setting up a platform is expensive, time-consuming and fraught with legal uncertainties. This is where the Silicon economy comes in: a platform ecosystem will take the place of isolated platforms, enabling a variety and coexistence of different logistics and industrial B2B platforms. The networking of these platforms is based on the International Data Spaces (IDS) standard. The Silicon economy will transfer IDS to an entire industry.

## SUCCESS

Supported by the German logistics industry, the Fraunhofer Institute for Material Flow and Logistics IML in Dortmund is currently developing open source-based components for services. Additionally it is designing components for the infrastructure of the platform ecosystem and thus for the AI logistics of tomorrow. The new so-called "logistics operating system" will meet the highest data protection requirements and can be used by any company, regardless of size. The IDS connector plays an essential role in this. As part of the Silicon economy development projects, a modular software system has already been created that logistics companies can use to easily integrate an IDS connector into their IT landscape without any further configuration or knowledge of the reference architecture model.

## COMPONENTS

- IDS Connectors
- IDS Identity Provider (CA, DAPS, ParIS)
- IDS Metadata Broker
- IDS App Store
- IDS Clearing House



## BENEFITS

- » *Development of open source components for secure, fully automated processing of business activities - from ordering to billing to transportation*
- » *Industry-wide standards through unified processes*
- » *Interoperability of companies*
- » *Creation of new business potential*
- » *Strengthening the logistics industry in Europe*





**Data Intelligence Hub**

*First secure marketplace to turn data  
and algorithms in value*





### CHALLENGE

Companies often lack transparency, security and trust with respect to the use of their data. For example, the companies involved in production, sales and distribution (supply chain) do not pass on important information to their business partners for fear of losing data and control. Deutsche Telekom facilitates data access with the Telekom Data Intelligence Hub by encouraging and enabling companies to exchange their data via a secure business ecosystem according to the principles of International Data Spaces.

### SUCCESS

The Telekom Data Intelligence Hub is intended to serve as a digital connection between companies and be both a source for commercial data acquisition and open data. The platform offers users tools for analysis in addition to acquisition, exchange and processing of data. Industry experts, e.g. programmers, data engineers, data journalists and data scientists, get the possibility to develop new business models, data-driven products or services. In a nutshell it is relevant for companies of all sizes and industries but also for universities, for example, that develop models for the combination of data and algorithms to attain new insights.

### COMPONENTS

- IDS Connector
- IDS Broker
- IDS App Store



### BENEFITS



» *Secure and controllable data exchange including administration of user rights*

» *Secure working environments for analysis tools to develop data-driven products and services*

» *Simple search and use of data beyond company borders*

Smart Parking

*Combining intelligent and fast parking system with customer rewards*



### CHALLENGE

Today up to 30% of inner-city traffic is traffic searching for free parking lots. On the other hand more and more shopping is done online which creates challenges to the stationary shops. Digital solutions powered by FIWARE have the potential to improve this situation. The drivers can be motivated to buy in the stationary shops if the stores provide essential information - according to the shoppers preferences.

### SUCCESS

Drivers in a city are not navigated to their target destination but to the closest free parking lot. Drivers can register their preferred shopping and marketing profiles. Anonymous customer marketing profiles can be matched with shops close to the parking lots. Matching shop offers are returned with hash codes for the possible offers. When the driver buys products or services in their respective shop his or her parking fee is covered by the shop.

Using the IDS connector provides sovereignty of data for the driver: His/her data will only be used for a single parking event and cannot be used for other purposes. Based on the provided APIs all functions or even parts of it can be used to implement additional smart parking solutions in the future.

### COMPONENTS

- IDS Connector



### BENEFITS

- » *Reduces traffic and air pollution in the cities*
- » *Additional business for shops in the city group of suppliers*
- » *Improves driving experience for the driver*



Smart factory web

*Blueprint architecture for open  
sustainable and resilient production  
ecosystems*

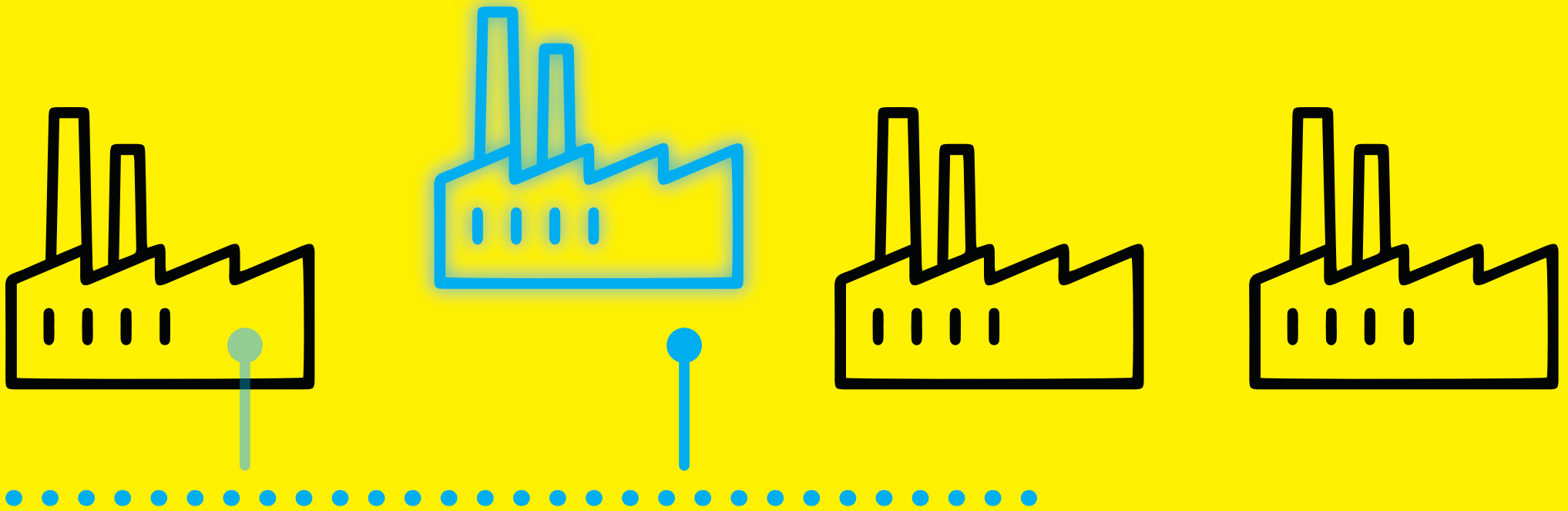

## CHALLENGE

Data exchange between partners is a challenging task, especially when critical production data from factories is involved. While the customers want as much information as possible, the producer is reluctant to share any data with unknown partners. The IDSA strives to create global secure data spaces in which data owners can choose how their data is used and distributed within a given domain (e.g. manufacturing, energy, healthcare, logistics).

Fraunhofer IOSB has developed the IDS OPC UA factory connector to connect smart factories over OPC UA to IDS. As use case we chose our marketplace for industrial production, the smart factory web (SFW), where factory owners offer their production capabilities to customers world-wide. By modeling their supply chains in the smart factory web, the factory owner can decide which partner and under which conditions and constraints the factory data can be used. For example, the factory owner can share information about a product with verified SFW customers while production data is only visible to partners of the active supply chain.

Our contribution aims to connect different standards such as those of the Industrial Internet Consortium (IIC), the International Data Spaces Association (IDSA) and the platform Industrie 4.0.

## SUCCESS

The OPC UA factory connector is the gateway to the IDS and connects any factory to any IDS participant such as other customers or the smart factory web. Our connector combines the benefits of IDS connectors (secure and standardized communication, data usage control) with the interoperability technologies and applications of Industrie 4.0. In consequence, any asset administration shell (AAS) in the factory can be published and secured over IDS. In order to realize our solution, we created an AAS model and instance for our bulk sorter in OPC UA format. In the smart factory web, we modeled supply chains with different partners. The OPC UA Factory Connector is able to retrieve the data from the AAS and verify which partner of our supply chain is allowed to use which data element. After the validation and enforcement of the data usage policies, the selected data elements are made visible in our demonstrator.

## COMPONENTS

- IDS compliant OPC UA Factory Connector
- IDS Usage Control (MYDATA)
- Smart Factory Web
- Asset Administration Shell



## BENEFITS

- » *Integration and interoperability with asset administration shell*
- » *Data usage control via IDS*
- » *New business opportunities by publishing factory capabilities and assets in marketplaces for industrial production*

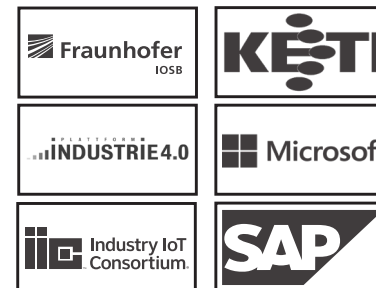

ONCITE

*Hybrid cloud solution for  
industrial edge computing directly  
on the shopfloor*





### CHALLENGE

To exploit the full value of data, companies must be able to capture, store, process and evaluate data efficiently and intelligently. This is even more important as companies today often need to exchange data with partners across the entire supply chain. Decision makers are faced with the question of how to react to these changes in the industrial landscape: How can companies exchange data with partners across the entire supply chain easily, fast, securely, and without losing sovereignty over their data?

### SUCCESS

With ONCITE, companies can process and store data on site before they exchange it over a public cloud – with data sovereignty being ensured across the entire process. ONCITE is a compact computing center that is based on edge cloud technology. At the heart of it is the IDS-certified trusted supplier connector. The user interface monitors and controls any exchange of data between two partners. Using the Connector, partners can evaluate data to use themselves or to make it available for being used by OEMs' systems.

**ONCITE** 



### COMPONENTS

- IDS Connectors



### BENEFITS

- » *Suppliers and manufacturers can make each other's data available for being used in digital processes*
- » *Companies can process and store data on site before they exchange it over a public cloud*
- » *ONCITE allows data exchange transactions in real time and at the highest possible level of security*



Horizontal supply chain collaboration

*Harnessing masses of data  
generated by sensors in logistic  
processes*

**CHALLENGE**

Today, supply chain stakeholders lack status information concerning their material flows, which increases their costs. Digitization provides the basis for optimizing material flow in supply chains. It establishes transparency, presents new possibilities for cost reduction in the process and helps identify logistic tasks that can be outsourced to third-party suppliers.

**SUCCESS**

Track and trace systems, in combination with digital services, can make the full supply chain more successful. Barcodes, 2D-codes or RFID technology can identify materials. At the same time, the digital services are digitizing the logistic processes, for example, repacking or validation of material in handling units.

These systems provide every stakeholder with necessary and trustworthy information via the IDS data structure. Based on the secure data exchange, further data-driven process automation, such as billing, is visible.

**COMPONENTS**

- SICK track and trace system
- IDS Trusted Connector
- Data Metadata Broker
- IDS Identity Provider (CA, DAPS, ParIS)
- Corda



**BENEFITS**

- » Digitized and trusted transparency of material flow in the full supply chain
- » Flexibility in generating new business models in the supply chain to reduce process costs
- » Reduced cost of fixed capital on stock



Trusted exchange for aeronautics

# *Trusted exchange for quality assurance in aeronautics*



### CHALLENGE

The scenario for trusted data exchange for aeronautics includes data exchange between engineers, design and testing center, and aviation companies across country borders. This means that different data protection laws apply. IDS connectors ensure that data can be managed in a safe and standardized manner, allowing for better condition monitoring and detection of anomalies for quality assurance. The connector development plays a crucial role in this scenario as cost reductions for quality assurance become possible. The implementation of the data sovereignty principles, following the IDS reference architecture model, guarantees on the one hand to control the access and the usage of data (cross-countries, cross-companies, etc.), on the other hand the creation of an ecosystem ready to be extended to satisfy new needs and communicate with existing companies using a common vocabulary.

### SUCCESS

Engineering has put in place some IDS open-source components for supporting the quality assurance process of AVIO Aero. Data can be exchanged in a trusted environment:

- Using different protocols and data formats
- Defining and enforcing rules for usage control
- Implementing the non-repudiation mechanisms
- Integrating the digital enabler platform for consuming data in a highly flexible way

### COMPONENTS

- IDS Connector
- IDS Clearing House



### BENEFITS

- » *Trusted data exchange between different establishments and countries*
- » *Usage of IDS open-source components for enabling the data exchange*
- » *Providing an ecosystem platform for processing and consuming data*

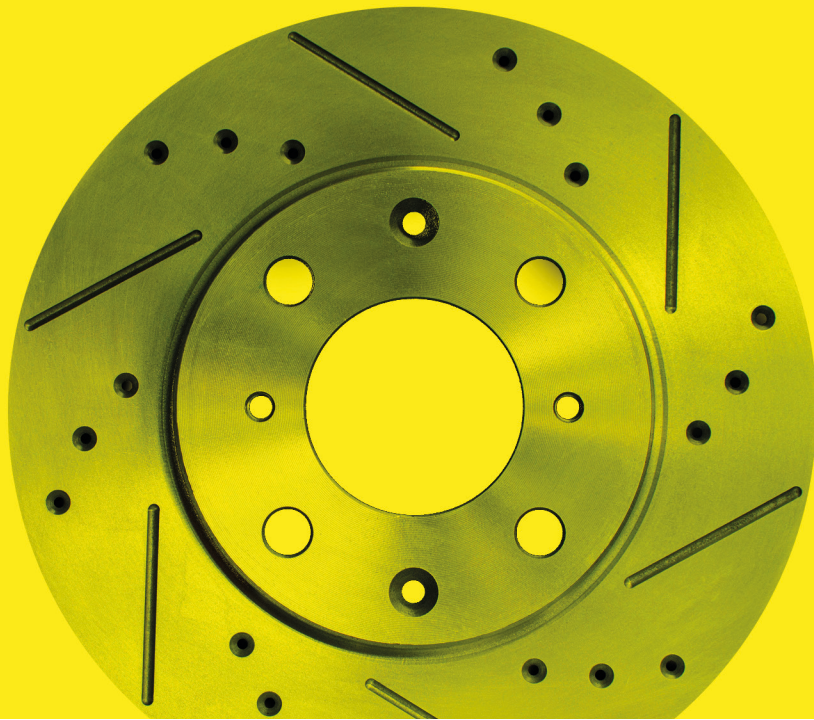

Supply chain manager

*Achieving transparency across  
automotive supply chains*



## Use case #13

### CHALLENGE

Volkswagen, thyssenkrupp and Fraunhofer Institute for Software and Systems Engineering ISST are reaching out for data sovereignty with focus on improvement of demand and capacity management (DCM) systems in automotive supply chains. The industrial partners mutually aim to optimize supply chains in terms of transparency, efficiency and sustainability assisted by the IDS. The idea is to make supply chains resilient and firm; long-term objectives become realistic by putting sensitive data, such as stocks, output volumes and production programs in bidirectional correlation. IDS represent the technological basis for that type of data exchange, supporting data sovereignty between organizations whilst complying high-level safety requirements.

### COMPONENTS

- IDS Connector
- IDS Connector Framework

### SUCCESS

Trust is one of the highest rated requirements for collaboration in industrial environments, such as material provider and productive consumer, e.g. automotive production. Especially when exchange of sensitive data is required purely trust is not sufficient due of the fact that access to IT systems is outside of human's control. A technical solution is mostly required to ensure data sovereignty on both ends, establishing trust by using technology.



VOLKSWAGEN  
AKTIENGESELLSCHAFT



Fraunhofer  
ISST



### BENEFITS

- » Exchange and usage of data leads to process improvements
- » Increased transparency in automotive supply chains
- » Establishing mutual trust enables policy enforcement

# FIREWARE TRUE (trusted engineering) connector

The FIWARE TRUE connector (FTC) is a connector for the IDS ecosystem. FTC enables the trusted data exchange in order to be an active part of an IDS ecosystem, a virtual data space leveraging existing standards and technologies, as well as governance models well-accepted in the data economy, to facilitate secure and standardized data exchange and data linkage in a trusted business ecosystem. The connector is compliant with the latest IDS specifications and can be easily customized to fit a wide spread of scenarios thanks to the internal separation of execution core container and data app. It is integrable with a lot of existing IDS services and totally configurable in terms of internal/external data format (multipart/mixed, multipart/form, http-header) and protocols (HTTP, HTTPS, Web Socket over HTTPS, IDSCPv2).

The TRUE connector is composed of three components:

- Execution core container (ECC), open-source project designed by Engineering. It is in charge of the data exchange through the IDS ecosystem representing data using the IDS information model and interacting with an external identity provider. It is also able to communicate with an IDS broker for registering and querying information.
- FIWARE data application, open-source project designed by Engineering. It represents a trivial data application for generating and consuming data on top of the ECC component.
- Usage control (UC) data application, a customized version of the Fraunhofer IESE base application for integrating the MyData Framework (a usage control framework designed and implemented by Fraunhofer IESE) in a connector.



# Eclipse dataspace connector (Edc)

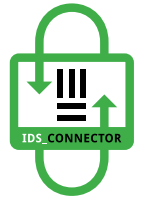

The Eclipse Dataspace Connector provides a framework for sovereign, inter-organizational data exchange. It will implement the International Data Spaces standard as well as relevant protocols associated with GAIA-X. The connector is designed in an extensible way in order to support alternative protocols and integrate in various ecosystems.

As such, the framework will be fully extensible and architected to integrate with other technology solutions in the following areas:

- Data transfer wire protocols for a variety of use cases including data streams, IoT data, and large data sets.
- Identity providers, including OAuth2-based implementations as well as distributed identity systems.
- Data storage, cataloguing, and taxonomy systems.
- Host environments from on-premise installations to multiple cloud platforms.

The connector will provide an open and publicly accessible solution for data providers and consumers, allowing them to concentrate on the use case at hand.

One of the guiding principles in developing the connector is simplicity and keeping the core small and efficient with as little external dependencies as possible to avoid version conflicts. We do not want to force any third-party dependencies onto our users, so we aim to avoid any of the big frameworks. Of course, if you want to use them, you still can add them to your extensions. The connector is a plain Java application built with Gradle, but it can be embedded into any form of application deployment.

Since the EDC is hosted as an Eclipse project contributions by the community are highly welcome.

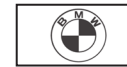

# Data – the raw material for our Economy

Business models develop out of data, values develop out of business models, and growth and prosperity develop out of values. International Data Spaces preserves the digital sovereignty of data ownership and forms the basis for smart services and innovative business processes worldwide. It is an ecosystem in which different participants can play by their own rules so they can implement their business models and protect their own interests – and those of their customers.



BECOME A MEMBER!

[www.internationaldataspaces.org](http://www.internationaldataspaces.org)

THE ADVANTAGES:

- ✓ *Implement use cases*
- ✓ *Drive global standardization forward*
- ✓ *Develop architectures*
- ✓ *Design sustainable business models*



OUR MOST IMPORTANT DOCUMENTS





This document is part of projects that have received funding from the European Union's Horizon 2020 research and innovation programme under grant agreements ID 825619, ID 768775, ID 872613, ID 958363, ID 824964, ID 953163, ID 951771, ID 101016175, ID 101017111ID 869991, ID 822064, ID 824988 ID 857065, ID 825030, ID 871481



#### LEGAL OFFICE:

International Data Spaces e. V.  
Fraunhofer Forum  
Anna-Louisa-Karsch-Straße 2  
10178 Berlin  
Germany

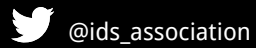

@ids\_association



International Data Spaces Association

#### HEAD OFFICE:

International Data Spaces e. V.  
Emil-Figge-Str. 80  
44227 Dortmund  
Germany

Phone: +49 (0) 231 70096 – 501

info@internationaldataspaces.org

www.internationaldataspaces.org